

Operations Manual

THE SEEKER

42' Golden Star



Welcome Aboard!

Thank you for choosing "The Seeker" as your charter vessel!

Set sail in comfort and style aboard a beautifully equipped vessel designed to deliver the ultimate cruising experience.

We trust this manual will help you become familiar with this boat. If you have questions about the boat or about places to visit, please do not hesitate to ask the AYC staff.

Contents

Welcome Aboard	-----	1
Specifications	-----	3 - 4
Pre-Departure / Departure Checklist	-----	5
Engine Operation Speed	-----	6
Approach and Docking	-----	6
Stopping the Engines	-----	7
At the Dock	-----	7
Fueling	-----	7
Holding Tank Pump out	-----	8
Anchor and Windlass	-----	8 – 10
Generator Operation	-----	11
Inverter Operation	-----	11
Barbecue Operation	-----	12
Stereo Operation	-----	12
Dinghy Information	-----	13
Water Tanks	-----	13
Hot Water	-----	13
Cabin Heat	-----	13
Heads and “Y” Valves	-----	14
Showers and Drains	-----	14
Ice Maker	-----	14
Refrigeration	-----	14
Stove / Oven and Crab Cooking	-----	14
Crab Cooking	-----	15
Waste Water System	-----	16
Fresh Water Diagram	-----	17
Bilge Pump and Thru Hull Diagram	-----	18
Fuel Supply Diagram	-----	19
Notes	-----	20
Stern Tie Instructions	-----	21
Dinghy Operation	-----	22

SPECIFICATIONS: “THE SEEKER”

- Running 1600 RPM – 1800 RPM produces speeds through the water of 8 – 9 knots and speeds over the bottom of 6.5 – 11.0 knots depending on currents. Fuel economy is about 6 – 7 GPH at these RPM’s. Running 2000 – 2200 RPM will produce water speeds of 10 – 12 knots and significantly impact fuel economy. Estimate it will increase to around 9 – 11 GPH.
- Sometimes in start up, an oil pressure gauge may stick. A little tap on the gauge glass activates it.
- When shore power is connected to the boat, it is absolutely necessary to ensure a good connection to the boat. After plugging into the boat and twisting to lock, gently pull on the plug to make sure it is in full twist lock position and tight. (if it is connected poorly; arching can occur resulting in the cord end being burned).
- Neither the stove top burners or the oven itself will work if the burner cover is down.
- **Please don’t take down the main canvas or remove panels marked as “Do Not Remove”.**
- The water tanks are stainless steel and will bank (“oil can sound”) when at certain percentages of full or empty.
- Anchor needs a little help over the roller on launch. It stops on the pivot pin sometimes.
- The following are the “Normal Run Readings”:

Port Flybridge

Oil 35 – 45
 Temp 190 – 195
 Volts 12.2 – 12.8

Starboard Flybridge

Oil 40 – 50
 Temp 185 – 195 (occasionally flutters)
 Volts 12.1 – 12.5 (lower matches port)

Port lower

Oil 35 – 45
 Temp 190 – 195
 Volts 12.2 – 12.8

Starboard Lower

Oil 40 – 50
 Temp 185 – 195
 Volts 12.2 – 12.8

SPECIFICATIONS

Hull ID Number	BZU42108F990
Documentation Number	1024429
VHF Call Number	WDA6236

LOA	42 ft (Minimum 48 ft of dock required)
LWL	38 ft 6 in
Beam	14 ft 8 in
Draft	4 ft
Displacement	33,000 lbs.
Engines	(2) Cummins Diesels @ 250 hp each
Propellers	(2) 24 inch Bronze 3 blade
Shafts	(2) 2 inch Stainless Steel
Fuel Capacity	410 gal (2) 175-gal side tanks (1) 60-gal center tank
Water Capacity	260 gal (1) 150-gal Aft tank (1) 90-gal Forward tank (1) 20-gal hot water heater
Waste Holding Tank	50 gal (1) tank under Galley floor
Generator	Onan 8 kW
Inverter	MS Series 3000W Sine Inverter 125A Charge
Engine Oil	Delo 400 15-40 wt
Transmission Oil	Delo 400 30 wt
Primary Anchor	45 lb stainless steel CQR w / 280' of chain
Emergency Anchor	35 lb CQR w/ 150' of chain
Cruising Speed (comfortable & economical)	7 - 10 Knots @ 1400 - 1800 RPM

PRE-DEPARTURE / DEPARTURE CHECK LIST

The following items should be checked prior to departure

1. Normal systems integrity, including sea-strainers clear and raw water seacocks open, oil levels normal, DC engine start voltage above 12v DC and coolant levels at appropriate level.
2. Relevant windows and doors closed. Aft Salon door should be closed during engine warm up to prevent fumes from accumulating in the Salon.
3. All gear secured /stowed to prevent shifting or falling while under way.
4. Unnecessary electrical systems turned OFF and appropriate underway switches and navigation aids turned ON as required.
5. Start engines early to ensure that a minimum of 5 minutes warm up time occurs, which is necessary to minimize wear and ensure reliable shifting of gears. Operate Engine room blowers if you like but **REMEMBER** to turn them **OFF**. Place the shifters in neutral and throttles to idle. Turn key switches to ON position at lower helm panel. Press the start buttons one at a time to start the engines. Each engine should start almost immediately; however, do not crank the engine more than 15 seconds at any one time. Wait at least 15 seconds before re-engaging the starter. Allow engines to idle at about 900 RPM's or slightly higher to a smooth idle. Check for oil pressure rise and silencing of the warning buzzers. **Check water flow from each exhaust, every time.**
6. Disconnect from shore power by first turning off the breaker on the boat electrical panel and then at the dock connection. Disconnect cord from dock power outlet and then disconnect the cord from the Starboard boat connection. Please instruct crew in this procedure. Not everyone is aware or familiar with locking tangs, power breakers dockside or the bezel ring attachments on the fittings. Store the power cord under the Flybridge seat on the Starboard side.
7. Check to see the crab ring and line are securely stowed on the Aft deck for travel.
8. Check to see the BBQ is securely stowed on the Aft deck or behind Flybridge helm for travel.
9. Check local wind & current conditions. "The Seeker" has a large amount of freeboard, which can be affected by the wind while maneuvering. Establish your route for departure and direct the sequence for release of all lines.
10. Shift gears at **idle RPM only**. A pause in Neutral is appropriate.
11. **Please do not remove fenders until clear of the marina. Also, keep a line handy as well.** Leaving fenders in place with a line quickly available will afford vital protection and options if circumstances go sour unexpectedly.
12. Once clear of the marina, store lines **securely** on the Aft deck. A loose line can easily get into the water and foul in the props. Store the fenders in the bow holders or secured to a rail. **Close Hatches please.**

ENGINE OPERATING SPEED

The normal engine (cruise) operating speed is 1400 - 1800 RPM's. This will produce a comfortable and economical cruising speed of 7 - 10 Knots. Maximum RPM is 2200. There are alarms for low oil pressure (less than 6 PSI on a system that operates on about 30 PSI minimum) and high water temperature (over 210 Degrees on a system that typically runs about 160–190 degrees maximum.) Thus, **relying on alarms only informs you when it's too late.** Check your gauges regularly.

APPROACH AND DOCKING

1. A minimum 50 feet of dock space is required (includes dinghy & bow pulpit).
2. Slow to idle early. Check gauges for proper readings. Oil PSI will drop to around 15-20 PSI at idle after cruising for a while.
3. **Before you get into the marina**, instruct crew / line handlers on your intentions and identify the critical lines to be applied first.
4. With everyone briefed on your intended plan, place dock lines on cleats and use all fenders deployed on both sides of the boat (just touching the water, please). It is far better to have all the bases covered than to flail about when faced with an unanticipated situation resulting from wind, current, traffic or a missed approach. Murphy loves boating !!
5. Check wind and current for anticipated effect on your maneuvering plans.
6. “The Seeker” has a large amount of momentum. **Use neutral a lot, go easy and stop the boat if the fenders are on the dock. Continuing will only roll the fender out of the way and hull scratches will result. Do not allow your crew to jump in an attempt to help with the docking process. A minor slip or miss judgment can result in a very unfortunate injury. If possible, have them step to the dock and have a line passed to them so they have both hands free when leaving the boat. Do not allow your crew to attempt to muscle the boat off from a missed approach. With the amount of weight and momentum “The Seeker” carries, injuries are likely if desperation pushing or pulling is attempted. GO SLOW.**

STOPPING THE ENGINES

Place the shifters in neutral and allow the engines to idle (stabilize and cool). Once they have stabilized and cooled, about 5 minutes minimum, turn the keys to the Off position one at a time.

AT THE DOCK

1. Tie the boat up at least twice, once for nominal control then for position and security. Check your line handler's cleatings. Reset fenders as appropriate. **Be sure no fender is located so as to obstruct the diesel furnace exhaust port, located on the Starboard side, a little Aft of the Starboard-boarding gate. Fenders can become hot and melt and or lines can catch on fire !!**
2. If applying shore power, make the boat connection first, **ensuring a tight and secure connection.** Turn the circuit breakers at the Electrical Panel to OFF and the circuit breaker at the dock power box to OFF, then plug into the dock power box and secure. Turn the circuit breaker at the dock power box back on and verify good polarity and acceptance at the Electrical Panel by turning on the circuit breaker on the boat.
3. Secure (turn OFF) unnecessary switches, turn on those switches that will be necessary for the stay and ensure the inverter is properly set to the "Charge" mode.

FUELING

Fill fuel tanks with DIESEL only. Close all Ports and doors to prevent fuel fumes from flowing to the lower parts of the boat interior. **Don't try to fill water and fuel at the same time.** Ensure you have the proper fill cap! Introducing diesel into the water system or water into the diesel system will result in very expensive repairs and are not covered by insurance. The fuel fill caps are located on the deck, on each side just Forward of the Sun deck area. Each side is filled separately and each tank has a capacity of 175 gallons. Disengage from conversation while fueling and listen carefully for the "full" sound of the fuel starting up the filler neck. Stop fueling and check the fuel site gauges in the engine room. Trying to second-guess the "full" sound will likely result in a messy and expensive fuel spill, either out the vent or the filler neck. Secure the filler cap back into the receiver. **Don't over tighten;** you only need to compress an "O" ring adequately.

HOLDING TANK PUMP OUT

There is just one holding tank and one pump out deck fitting located on the deck just Forward of the Starboard Salon door. Remove the deck fitting. Position the suction nozzle hose end securely in the deck fitting opening. Ensure you have a good airtight seal. Have one of your crew turn on the machine while you simultaneously open the ball valve associated with the suction nozzle. Empty the tank. Call for the pump to be turned off while you simultaneously close the ball valve. Wait a few seconds for the nozzle to drain then remove the nozzle. **Partially refill the tank with fresh water through the pump out deck fitting and pump out again. This helps to keep odors from accumulating in the boat.** When finished, place the nozzle in salt water and briefly restart the pump and open the ball valve for a short period to flush the nozzle for the next user. Close the ball valve and stop the vacuum pump. Secure the deck fitting. **Don't over tighten;** you only need to compress an "O" ring adequately.

Note: It is possible to empty the holding tank, in Canadian waters only, by pumping the waste overboard using the waste pump in the Engine room. Open valve in the engine room, forward of the STBD engine. Turn ON the waste pump breaker on the 12v DC panel. 10 minutes maximum should empty the tank.

We strongly recommend emptying the holding tank every other day!

Don't try to go too long without emptying the tank. Overfilling will force material into the vent line and result in an inability to subsequently empty the tank. A blocked tank is just as expensive to a charterer as a blocked head !! Forewarned ! There is a gauge near the galley steps; When it reads $\frac{3}{4}$, you are very close to full.

ANCHOR AND WINDLASS

The primary anchor is a stainless steel 45 lb. CQR plow type anchor with 300 ft of 3/8" chain, secured at the bitter end in the chain locker. The windlass is a Maxwell, which is controlled by a foot press pad at the windlass **Do not try to use the switch at the helm station.** The system is enabled by engaging the 12v DC breaker switch, a large red knob (it takes a little force) as indicated on the panel, located in the Forward cabin on the Forward bulkhead next to the chain locker door (a green LED will illuminate.)

Lowering the Anchor

The chain rode is marked at lengths of 25', 50', 100', 150', 200', 250' & 300'. The marking at 25' is **RED and WHITE** paint on the chain. The markings for 50', 100', 150', & 250' is by use of **RED** paint on the chain. The final mark at about 280' is **RED and YELLOW** paint on the chain. **STOP if you reach the YELLOW mark.** Check the depth of the water carefully. Add 7 ft for the height of the bow above the water and REMEMBER to allow for predicted tide changes to calculate the minimum required rode. Water that is 15 ft deep now, may be 21 feet deep in the middle of the night. A **minimum** Scope of 6 to 1 is recommended for "The Seeker". However, more is required if winds or currents are present.

Example: Depth: 20 ft + Bow height: 7 ft + Tide Change (+3 ft) = 30 ft of total depth
 30 X 6 = 180 ft of rode minimum

It is preferable that the anchor be lowered using the footpad switch at the Bow (Port Side) versus the switch at the lower helm. However, either is possible. With the 12v DC power on (Master ON / OFF Button on the forward bulkhead in the forward cabin) depress the footpad, located near the Bow on the deck marked as down (Left of two footpads when facing Forward – **Left = Lower**) to begin lowering the anchor. After enough chain has been let out (look for the first Red Mark) to ensure the anchor has reached the sea bed, begin to maneuver in reverse slowly (standard hand signals recommended). Use short bursts on the shifters, while letting out more chain to the full desired scope and ultimately setting the anchor. With the full-identified amount of chain released from the locker, maneuver in reverse with short bursts on the shifters to set the anchor. Watch for the chain to tighten and increase its angle from the bow to the water. When this happens, pause with the shifters in neutral for a short time (30 seconds or so) and watch for the angle to decrease once again to the water. Locate two stationary objects near or on shore, to use as a range in determining if the boat is continuing to move in reverse or if it's springing back to a Forward location. Once you have determined through a couple of tests that the anchor is set and the boat maintains a stationary Forward and Aft position, recover the footpad switch and turn off the windlass breaker. Lastly, continue to cool down the engines and shut them off.



Raising the Anchor

Start and warm up the engines. Turn ON the circuit breaker, the red knob on the windlass panel in the Forward cabin. Obtain the hose stored under the sink on the Aft deck and connect it to the faucet near the windlass footpad. Turn on the 12v DC circuit breaker at the helm station for the seawater pump. Maneuver the boat slowly toward the anchor (standard hand signals recommended.) Take up slacked chain as it becomes available with the windlass using the Starboard footpad switch (Right of two foot pads when facing forward – **R**ight = **R**aise), and releasing the footpad when under load. As the chain is hauled in, turn on the faucet and rinse down the chain, removing mud, shells and grass. Maneuver over the anchor, stop the windlass and break the anchor out using the boat's momentum. Once broken loose, raise the anchor with the windlass. Slow way down as the anchor approaches the roller. Allow the anchor to assume an upright position and finish hauling on board, **slowly**. Once secure, recover the footpad switch, rinse deck if needed, turn off all windlass and seawater pump breakers. Secure the hose. **Do not pull the boat to the anchor using the windlass. Do not use the windlass to pull the anchor free from the bottom. Keep hands free from windlass when hauling the anchor in.**

Spare anchor

A spare 35-lb. CQR anchor is available for emergencies only. It is located under the Forward berth and can be removed by carefully lifting out and up through the overhead emergency hatch. **Use of two anchors for normal anchoring is strongly discouraged.** The rode for the spare anchor is 5/16 in chain and only about 150 ft, located in the Aft cabin in the Starboard locker. Stern tie to shore if necessary is the best option versus using a second anchor at the Stern. A line for this is located in the Aft cabin – Aft port corner cabinet.

GENERATOR OPERATION

Set the selector switch to the OFF position. Start the generator by pushing the START button and **check to see that water is flowing from the exhaust port**, Starboard side, ensuring proper cooling is taking place. Allow the generator to warm up for about 3 minutes. Move the Selector switch to the generator position and 110v AC is available for use from the generator. When the generator is no longer required, remove all loads from the circuits (turn off devices and breakers). Allow generator to run for a few minutes with no load on the circuit. After about 3 minutes, turn the selector switch back to the OFF position. Then press the STOP button for the generator until it has completely stopped.

If the generator fails to turn over when the Start button is pushed, Check the following: Switch on Panel at generator must be set to “Control”. The Fault Breaker on the control panel located left of the main generator case may need to be reset on a rare occasion. To change the fuse, remove 6” round cover on top of the generator case. The inline fuse should be visible at this time. Replace fuse if bad (25 AGC) Reinstall cover Plate.

Fault Breaker location:

“Control” Switch location

In Line Fuse location, behind:



INVERTER OPERATION

The Inverter should be left ON all times. The remote panel should show the INVERT mode light on for proper operation of 110v items on the boat.

DO NOT Operate Electric Heaters, Water Heater or Ice Maker while on the Inverter Only.

BARBECUE OPERATION

The barbecue is a Newport Gas Grill by Magma. It is stored on the Aft Deck in a plastic container.

- Unzip the Starboard corner zipper.
- If not already connected, gently and firmly insert the Propane valve into the connector on the right side / end of barbecue. Insert completely with the control valve facing forward, then rotate clockwise 90 degrees so the control valve is facing up. Pull out gently to make sure the valve is secure. Then attach the propane canister by gently screwing it onto the valve.
- Remove barbecue and mount it on the rail as noted in the picture.
- If not already connected, gently and firmly insert the Propane valve into the connector on the right side / end of the barbecue. Insert completely with the control valve facing forward, then rotate clockwise 90 degrees so the control valve is facing up. Pull out gently to make sure the valve is secure. Then attach the propane canister by gently screwing it onto the valve with a counter clockwise motion.
- Turn the gas on as indicated on the valve and press the ignition button.
- If it is not lighting for some reason, use the manual lighter located in the cabinet above the Aft Deck basin.
- After lighting, turn gas knob to cooking setting and close the lid to allow it to warm up.



- After using the barbecue. Please clean it for the next use by you or anyone else.
- After cooling, remove barbecue from the rail and return it to the plastic container.
- Reposition / closes up the canvas in the reverse order and secure.

STEREO OPERATION

The stereo system is installed above the chart table. It is connected to an AM/FM antenna. It also has a Bluetooth connection and a USB port (underneath). If you connect a smartphone or tablet you can use voice commands.

Each speaker (Salon, FWD & AFT Staterooms, Sundeck and Flybridge) can be adjusted with individual dials near the speaker.

DINGHY

The dinghy is a Zodiac rigid bottom inflatable. Oars should be left securely strapped into the Velcro fasteners when not being used. **Please keep the dinghy clean, as dirt and gravel will wear the fabric. Don't run the dinghy onto rocks or beaches.** If it must be beached, turn the motor off early and tilt up well before reaching the shore. Plan to get your feet wet and lift the dinghy onto the shore using two or more people. Tie it off securely, allowing for tide changes while ashore, using the polypropylene line & Mushroom Anchor from under the basin on the Aft deck. The launching and recovery procedure is user friendly. Detailed instructions are located on page 22 and on a removable sheet at the back of this manual. Remember to take and wear life jackets when using the dinghy.

WATER TANKS

There are two water tanks on “The Seeker” and they must be filled individually. The fitting for the Aft, 150-gallon tank is located on the transom on the Starboard side, inside the swim platform shower door. The fitting for the Forward, 90-gallon tank is near the bow on the deck near the windlass switch. Water level gauges are located at the lower helm station.

Selector valves are located on the Forward portion of the Starboard bulkhead, just behind the battery box in the Engine room. The valve manifold is labeled for each tank. Open the appropriate valve to draw water from the selected tank. It is suggested that the front tank be used first.

HOT WATER

Hot water can be provided by AC dockside power, AC power from the generator or when operating the engines. The hot water tank has a capacity of 20 gallons. Do NOT use Inverter only.

CABIN HEAT

Cabin heat is provided by a diesel fired forced air furnace with outlets in each cabin, the Galley and Salon. The controls are located to Starboard at the top of the stairs leading from the Galley area to the Salon, just above the Electrical Panel. To operate, turn the toggle switch to on and set the thermostat to the desired temperature. Aft cabin & Forward cabin have adjustable vents (rotate center knob on vent). IF, connected to shore power, a small electric radiant heater is possible. **Do NOT use inverter only to operate an electric heater.** Turn thermostat down and allow furnace to stop. Then turn off Toggle.

HEADS AND WYE VALVES

Each head uses a Par quiet flush toilet. They operate electrically and use pressurized fresh water. To use, the appropriate circuit breaker must be ON, i.e. Aft head or Forward head. In addition, the fresh water breaker must be ON. In normal operation the wye valves are directed to the holding tank. The wye valves located in each head cabinet can be repositioned and thru hulls opened to pump the contents directly overboard. This is strongly discouraged, as it is illegal and finable if discovered during a boarding inspection. **NOTHING** goes into the head except what you have eaten and SMALL amounts of one-ply biodegradable marine toilet paper. Everything else is to be placed in small plastic trashcan liners and disposed of ashore. **This includes any/all feminine hygiene products.**



SHOWERS AND DRAINS

The showers are standard, with hot on the left and a general cut off valve in line after the hot and cold valves. Shower drains usable when the appropriate 12v DC breaker is turned ON, i.e. Aft sump / Forward sump. Please note, the only clearable strainers other than the shower scupper grates before the pumps, are in the sump pump boxes. Forward sump box is under the Forward dinette seat. The Aft pump is under a floor hatch at the foot of the Aft cabin berth. USE CAUTION.

ICEMAKER

To operate icemaker on the Aft deck, ensure fresh water pump and the icemaker are both turned ON. The **fresh water pump** at the 12v DC panel & the **icemaker** at the 110v AC panel. Ensure water line valve (located under the Aft basin) is set to open. Also, the icemaker must be turned ON at the icemaker. (Bottom center, under door). **The setting of “3-5” is typically sufficient.** Do not run the icemaker with the inverter only.

REFRIGERATION

The refrigerator / freezer operates on either 110v AC or 12v DC. Use the 110v AC only when using dockside shore power or the generator. A setting of about 3 ½, about 34 degrees and adjust from there. There is also an icemaker / refrigerator located on the Sun deck. Refer to “ICEMAKER” section for operation.

STOVE / OVEN

The stove and oven operate only on 110v AC. They can only be operated using either dockside shore power or the generator. ***Cover must be up to use and the oven light only works when stove/oven is on.***

CRAB COOKING

This process can make a big difference in your meal, cleanup and overall satisfaction. Rule number one: These are not East coast blue crabs so **don't try to cook them live or whole !!** From the beginning, with at least one licensed individual on board. **1)** Fresh bait such as salmon heads, chicken backs, turkey necks, etc. **2)** Mud or sand bottom **3)** Incoming or outgoing tide (moving water) **4)** Crab from the bow, well away from snagging rudders or props. **5)** 15 minutes on the bottom before pull, then pull up rapidly when time's up. **6)** Return females and shorts (less than 6 ¼" across back of carapace) **7)** Don't chuck males into bucket of water unless you want limbless veterans. Turn them upside down and when calm and under control whack smartly on their sternum and they will expire quickly. When clearly dead remove entire upper half shell forcibly and dispose of it. Break the crab in half on centerline. Shake out gelatinous innards; pick off feather like gills, mouthparts and tail. All that's left is legs and hip girdles. **(Please wash any debris off boat before it dries)** **8)** Get 1" maximum salt water from bay (not marina) in a cooking pot and bring to a boil. Once water is boiling, place crab halves in water and bring back to a full boil. Put the lid on and steam for 15 minutes. Pour water off. Blanch with fresh salt water and start eating. More meat in hip girdles than you might expect. Use a crab toenail for picking out meat. Enjoy.

The alternative: Boiling these crabs live or whole results in a crab fighting you on the way in and taking up much more space. It takes an enormous time to bring the water to a boil. Green frothy smelly boil over and resultant mess, and the crab are covered with the same smelly green frothy mess. **DON'T DO IT !**

The Seeker Waste Water Diagram

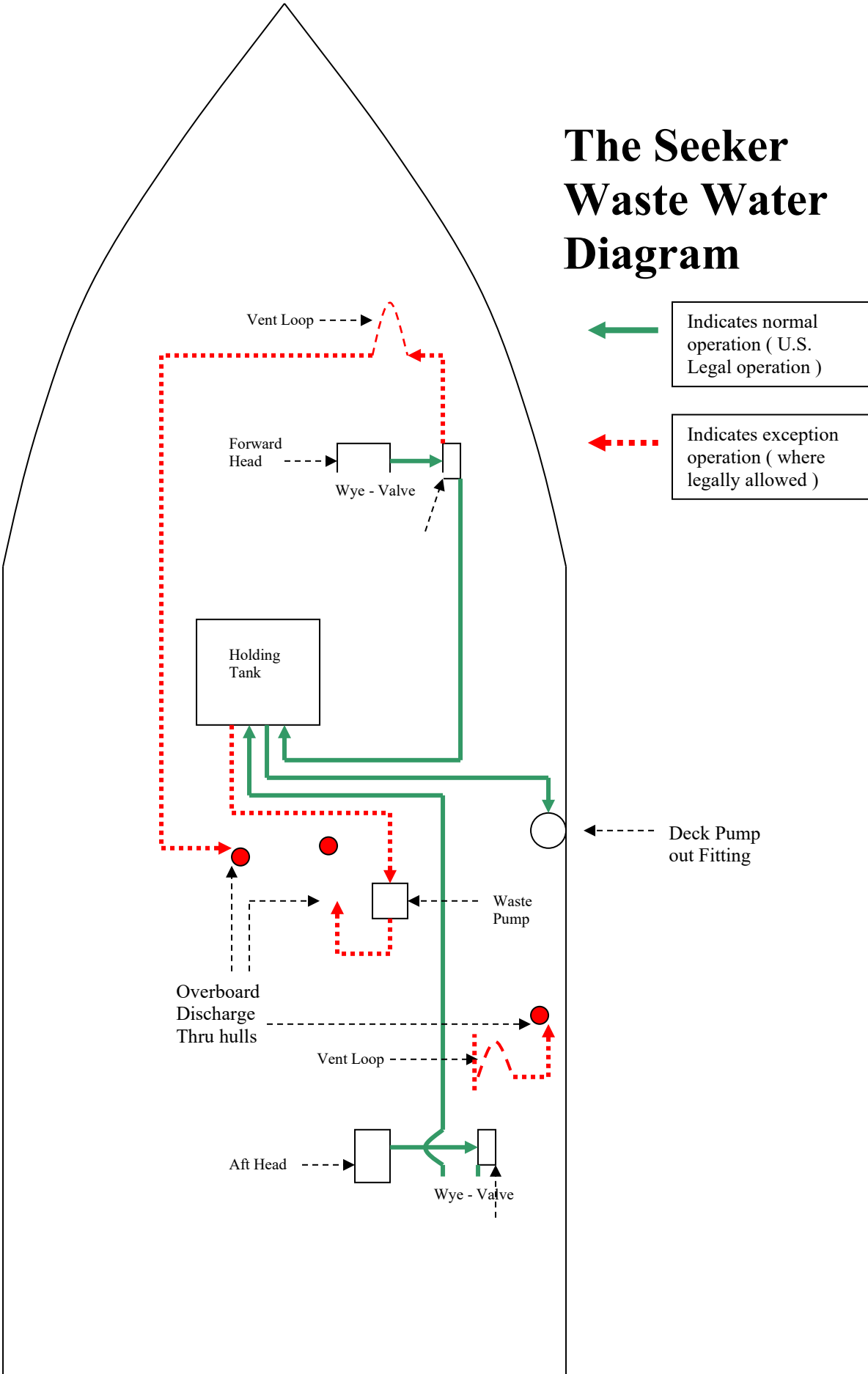

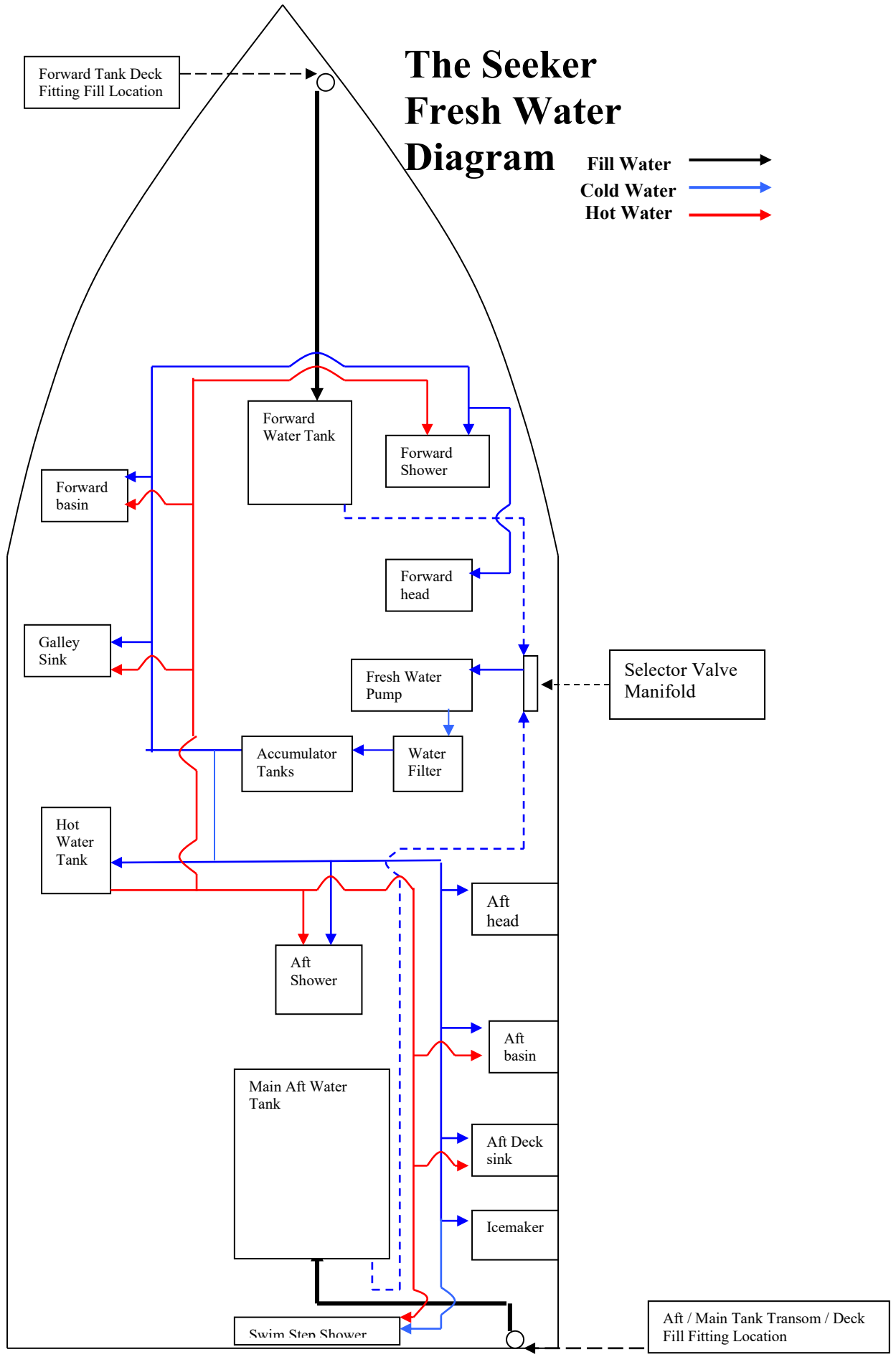

Bilge Pump and Thru Hull Diagram

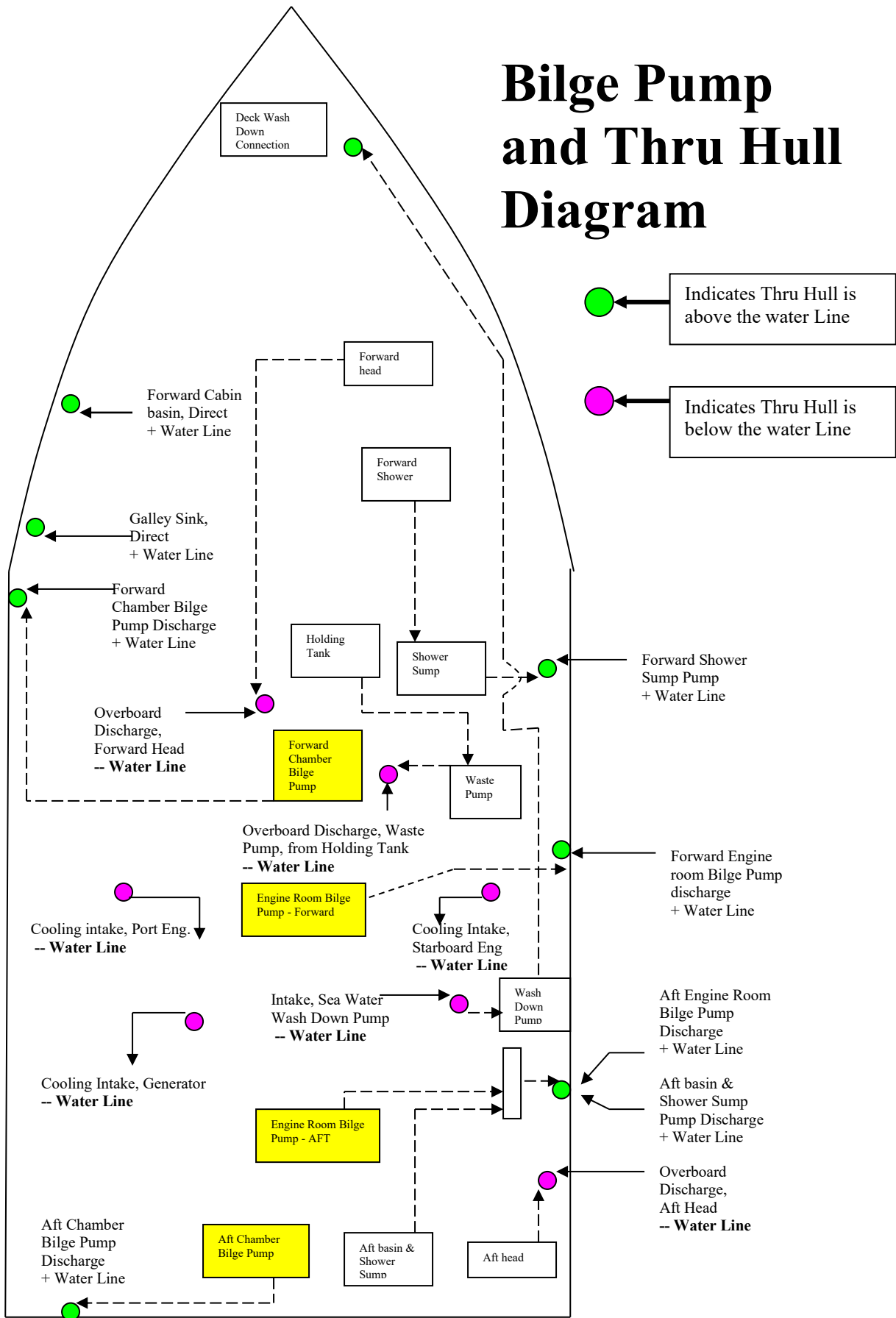

The Seeker Fuel Supply Diagram

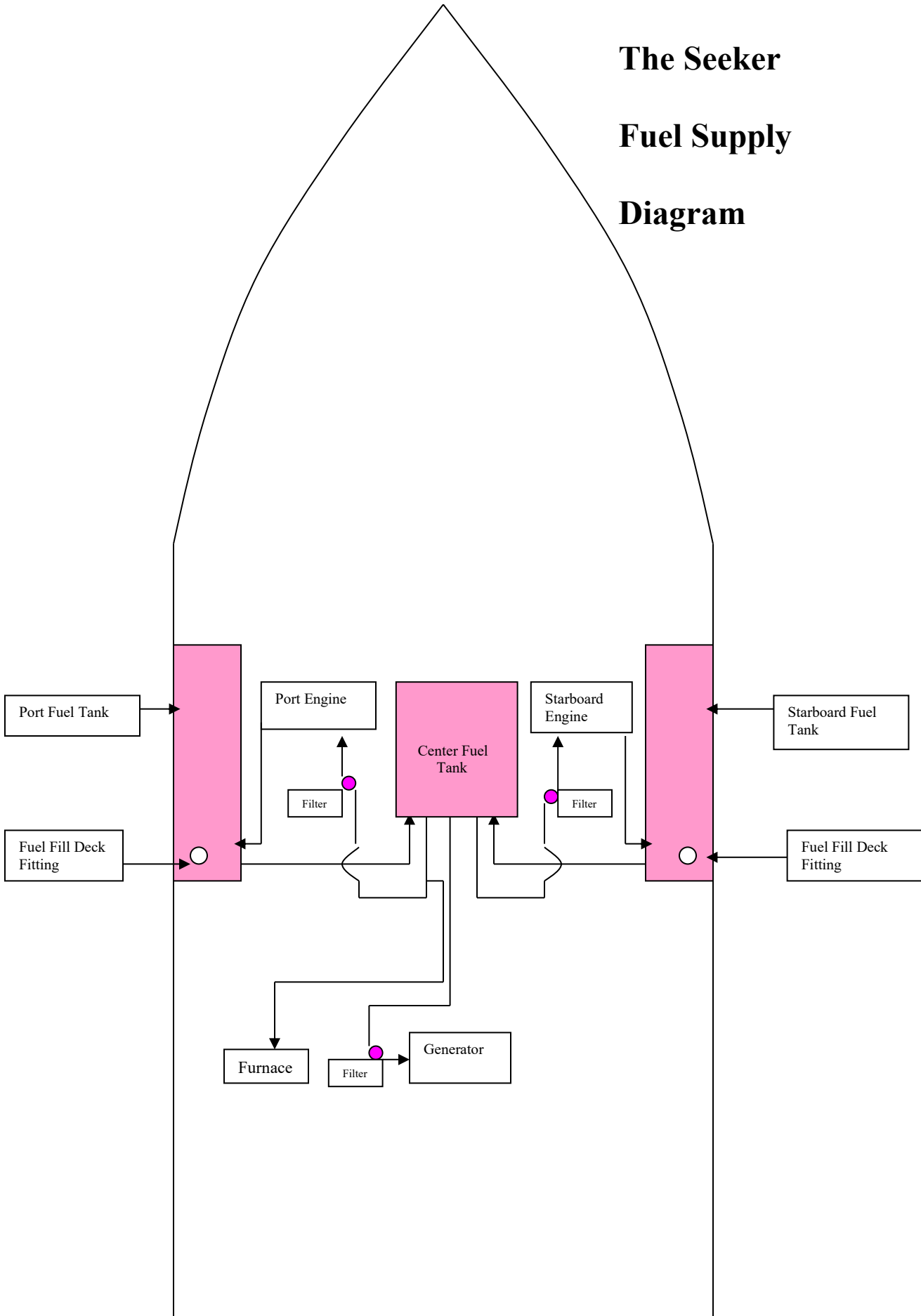

INSTRUCTIONS FOR USE OF STERN TIE:

A reel of flat line is located on the Aft Deck at the Port side, Aft Corner.

This 400 feet of flat line takes up considerably less space than a standard line would and carries a strength rating of 4,400 lbs.

While the line is strong, it needs to be properly used and cared for and is expensive to replace. Take care.

Double line use:

- Feed out line under the surround, just inboard of the corner mooring post.

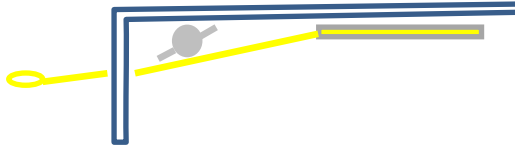

- Take the end of the line to shore and route it around a suitably solid anchor point. This should be something that will allow the line to slide around it during retrieval.

(DO NOT USE ANYTHING WITH CREOSOTE, TAR, PITCH OR ABRASIVE SURFACE)

- Return the end of the line back to the boat.
- Secure the loop on the end of the line to the forward arm on the Post

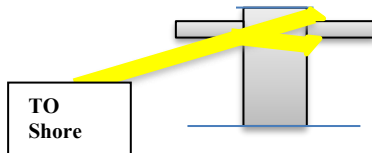

- Tighten the line to shore by taking up the slack MANUALLY.
- Once the slack is taken up, securely cleat the line on the post.

(DO NOT USE THE REEL TO TIGHTEN THE LINE)

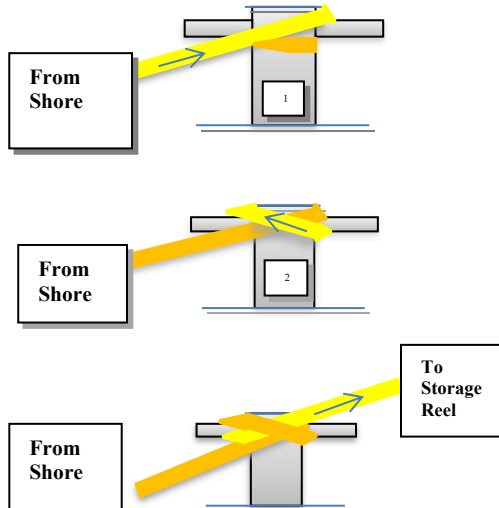

- Take up excess line at this time onto the storage reel.
- When ready to release, un-cleat the line from the post. Remove loop end from the post and release to the water. Begin to retrieve the line, taking it up on the storage reel. If the line becomes stuck on shore, it will be necessary to return to shore to solve the issue. DO NOT try to force or pull harder on the line to free it.

NEVER TIE THIS LINE IN A KNOT

INSTRUCTIONS FOR USE OF DINGHY: Launching dinghy

1. Retrieve dinghy key from salon chart table small drawer
2. **Turn ON dinghy breaker** located under salon aft deck step
3. Check tubes to ensure they are full of air with no obvious deformities observed
4. If tubes appear to be low on air, inflate using air pump from lower cabinet on aft dec
5. Release the dinghy bow security strap securing dinghy to stern of boat and secure to stern of boat
6. **Tilt motor to UP** position using control located on helm shifter to **clear the tubes without damage** when lowering dinghy
7. Pull out safety locking gin from winch post gate
8. Press the winch post switch DOWN to lower the dinghy
9. Release davit cable loop from the dinghy stern lift hook and hang from winch post reinserted lock pin.
10. Tighten treaded dinghy transom lock to secure motor to dinghy transom
11. Tilt engine to DOWN position using control located on helm shifter
12. Secure dinghy to main boat with line, which is tied to the dinghy bow or stored in lower cabinet on aft deck
13. Remove (pull) both latch travel pins securing dinghy to swim platform to free dinghy from boat
14. Activate both latches to release dinghy (**GENTLY pull up on release handle**)
15. Open bow locker and **OPEN the vent on the fuel tank** (turn counter clock wise ¼ turn)
16. Turn ON battery switch under aft seat – ¼ turn clockwise
17. Insert key and turn to start motor
18. Check to ensure a stream of water is flowing from the upper rear of motor for cooling

INSTRUCTIONS FOR USE OF DINGHY: Retrieving dinghy

1. Secure dinghy to main boat with line
2. Turn motor OFF
3. **Turn OFF battery switch** under aft seat – ¼ turn counter clockwise
4. Latch dinghy bow to swim platform
5. Latch dinghy stern to swim platform
6. Insert both latch travel pins to secure dinghy bow and stern
7. Tilt motor **UP all the way, careful to clear the tube without damage**
8. **CLOSE the fuel tank vent** (turn clock wise ¼ turn)
9. Loosen threaded transom locking handle ALL THE WAY which secures engine to transom
10. Place winch cable loop on the dinghy transom lift hook
11. Press the winch post switch **UP** to raise the dinghy
12. Be sure engine bracket is lifting off of transom on near side as dinghy raises
13. Continue to raise dinghy with winch until hook enters bracket on winch housing
14. Once the transom piece is seated securely in winch post housing, replace davit security pin in winch post gate
15. Secure dinghy bow line to the dinghy to ensure it does not fall into the water & foul the boat propellers when boat is underway
16. **Turn OFF dinghy breaker** located under salon aft deck step
17. **Tilt motor to DOWN position** using control located on helm shifter
18. Reattach securing strap from transom of main boat to bow of dinghy
19. Return dingy key to salon chart table small drawer